

ISUZU D-MAX
FURY



isuzu.co.uk

ISUZU
THE PICK-UP
PROFESSIONALS



A FORCE TO BE RECKONED WITH

With a motorsport bloodline born in the rallying heartland of the Scottish and Welsh forests, our newest recruit is one very special edition.

Inspired by our British Cross Country Championship rally truck, the Isuzu D-Max Fury is powered by a 2.5 litre, 163 PS twin-turbo engine, meaning it won't be left lagging on any road. And with its head-turning Magma Red paintwork and a custom-designed interior, the adrenaline continues in its design.

Yet for all its pulse-racing heritage, the Isuzu D-Max Fury is no show-pony. On or off road, every day, there is no compromise. Our outstanding 4x4 shift-on-the-fly adapts to any terrain at the touch of a button and our 3.5 tonne towing capacity is now legendary.

Comfort and luxury are built-in; and with fuel economy of 38.7 MPG (combined), the Isuzu D-Max Fury delivers the complete package of economy, practicality and performance you'd expect from Isuzu. And with our best-in-class, 5 year/125,000 mile warranty;* complete peace of mind comes as standard from the Pick-up Professionals.

isuzu.co.uk     

*Which occurs first) applies to all new 4x4 models

THE ISUZU D-MAX FURY DIFFERENCE

WORK HARD AND PLAY HARD.

LUXURIOUS

A powerful vehicle does not have to be uncomfortable. The interior has been beautifully fitted, soft enough for comfort, yet still designed for longevity, packed with everything you need to ensure a pleasurable journey.

CAPABLE

With an incredible towing capacity of 3.5 tonnes, the Isuzu D-Max Fury is class-leading. Together with a 2.5 litre twin-turbo common-rail diesel engine delivering 163 PS (400 Nm of torque) and 4x4 shift-on-the-fly, the Isuzu D-Max Fury is a force to be reckoned with.

RELIABLE

For complete peace of mind, all new Isuzu D-Max models come with a 5 year (or 125,000 miles) warranty (whichever occurs first).



CHOSEN TO PERFORM

THE ISUZU D-MAX FURY HAS STYLE AND SUBSTANCE.



4X4 SHIFT-ON-THE-FLY

The Isuzu D-Max Fury makes every journey a pleasure, whether in town or in country.

A turn of a dial mounted behind the gearstick engages four-wheel drive. Another turn selects low gears and lets you automatically crawl up and over whatever is in front of you.

Clever suspension cushions the ride without depriving you of that essential 'feel' for whatever you are driving over and hill descent is controlled by automatic engine braking.



TWIN-TURBO ENGINE

Our re-engineered 2.5 litre twin-turbo common-rail diesel engine produces 163 PS maximum power and delivers 400 Nm of torque between 1,400 and 2,000 rpm.

That and it's 3.5 tonne towing capacity makes the Isuzu D-Max Fury the perfect work-mate.



SUPERIOR FUEL ECONOMY

38.7
MPG
COMBINED
CYCLE



OFF-ROAD CAPABILITY

For full information regarding dimensions and capacities, see rear of brochure.

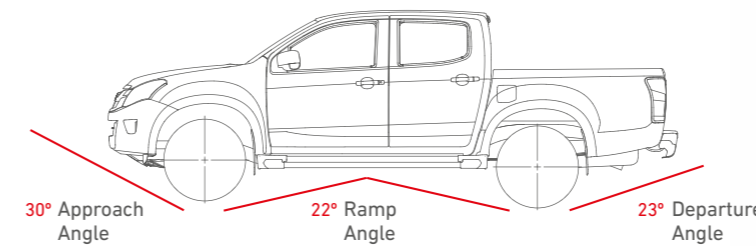

2.5 litre twin-turbo charged engine



STAND OUT FROM THE CROWD

THE ISUZU D-MAX FURY IS NO SHRINKING VIOLET.

With an extensive range of unique features, inside and out, this special edition model truly makes a statement. Available only in Magma Red, it's designed to be fun, but capable and fully fit for purpose.

Available in manual and automatic transmission as:

- 4x4 Double cab

Available only in:



Magma Red

MAKE A STATEMENT

- 4 x 17-inch dark grey alloy wheels
- Dark grey front grille with red Isuzu logo
- Cosmic Black rear tailgate handle
- Cosmic Black door handles
- Cosmic Black mirror caps
- Gunmetal Grey Aero side steps



TRULY UNIQUE, INSIDE & OUT

EVERY JOURNEY IS
AN ADVENTURE.

Uncompromising performance does not mean that you have to compromise on comfort or style. Inside our Isuzu D-Max pick-ups, the emphasis is on allowing the passengers to relax and the driver to feel at ease behind the wheel.

TOTAL COMFORT

- Black cloth seat trim
- Leather steering wheel with red stitching
- Double DIN CD/Radio/iPod/Bluetooth® connectivity
- Rear view mirror camera
- Fury branded carpet mats
- Leather gear stick gaiter with red stitching
- Chrome heater switches

OPTIONAL EXTRA

- Black/red Fury leather interior trim

FRONT BUMPER MOUNTED LAZER LIGHTS
OFF-ROAD TYRES
UNDER ARMOUR

MOUNTAIN TOP WITH SPORTS RAILS +
CROSS RAILS + ALUMINIUM BIKE RACKS
BLACK/RED FURY LEATHER INTERIOR TRIM



CREATE YOUR OWN

MAKE YOUR ISUZU D-MAX FURY
EVEN MORE INDIVIDUAL.

Our range of accessories allow you to create a truly
unique vehicle, exactly suited to your needs.

LOAD AREA COVER & CANOPY RANGE

- Black Roll 'n' Lock cover
- Mountain Top aluminium lid with sports rails
- Cross bars for Mountain Top with sports rails
- Aluminium cycle carrier
- Truckman Grand Leisure canopy

EXTERIOR STYLING

- Motorsport under armour
- Cooper Discoverer off-road tyres
- Lazer lights: front bumper mounted
- Lazer lights: sports bar mounted
- Rear style bar

INTERIOR STYLING

- Black/red Fury leather interior trim

INTERIOR TECHNOLOGY

- Pioneer AVIC-F70DAB Multi Media Sat Nav Unit



REAR STYLE BAR MATT BLACK



ALUMINIUM CYCLE CARRIER



MOUNTAIN TOP LID: SPORTS RAILS



TRUCKMAN GRAND LEISURE CANOPY



BLACK ROLL 'N' LOCK COVER



ALUMINIUM CYCLE CARRIER



MOUNTAIN TOP ALUMINIUM LID: CROSS BARS



LAZER LAMP KIT: SPORTS BAR



LAZER LAMP KIT: FRONT BUMPER



PIONEER AVIC-F70DAB MULTI MEDIA SAT NAV UNIT



BLACK/RED FURY LEATHER INTERIOR TRIM



COOPER DISCOVERER OFF-ROAD TYRES



MOTORSPORT UNDER ARMOUR



BLACK LEATHER INTERIOR TRIM

VEHICLE SPECIFICATIONS

	ISUZU D-MAX FURY
EXTERIOR	
Integrated fuel filler cap	■
Daytime running lights	■
4 x 17-inch dark grey alloy wheels	■
Body coloured bumpers	■
Locking wheel nuts	■
Cosmic Black door handles	■
Cosmic Black tailgate handle	■
Black rear bumper	■
Dark grey front grille with red Isuzu logo	■
Cosmic Black folding heated door mirrors with side indicator repeaters	■
Projector headlamps	■
Gunmetal Grey Aero side steps	■
SAFETY & SECURITY	
ABS + ESC + TCS	■
Door-open warning light	■
Front, side & curtain airbags	■
Height-adjustable front seatbelts	■
Three-point rear seatbelts	■
Security-etched glass	■
Insurance-approved immobiliser	■
Remote central locking	■
ENTERTAINMENT	
Double Din CD/Radio/iPod/Bluetooth®	■
Rear view mirror camera	■

	ISUZU D-MAX FURY
INTERIOR	
Front electric windows	■
Rear electric windows	■
Low fuel warning light	■
Rev counter	■
Air circulation system	■
Accessory power point	■
Cigarette lighter socket	■
Front door cup holders	■
Driver and passenger sun visors	■
Height adjustable front headrests	■
Height adjustable rear headrests	■
Reclining front seats	■
Heated rear screen	■
Height adjustable steering wheel	■
Height adjustable driver's seat	■
Carpet floor trim	■
Front seatback map pockets	■
Centre rear armrest	■
Rear heating ducts	■
Leather steering wheel with red stitching	■
Leather gear stick gaiter with red stitching (Manual only)	■
Driver and passenger reading lights	■
Black cloth interior	■
Fury branded carpet mats	■
Chrome heater switches	■

OPTIONAL EXTRA*	
Black/red Fury leather interior trim	-

ISUZU D-MAX FURY DIMENSIONS 4X4 DOUBLE CAB

All measurements in millimetres

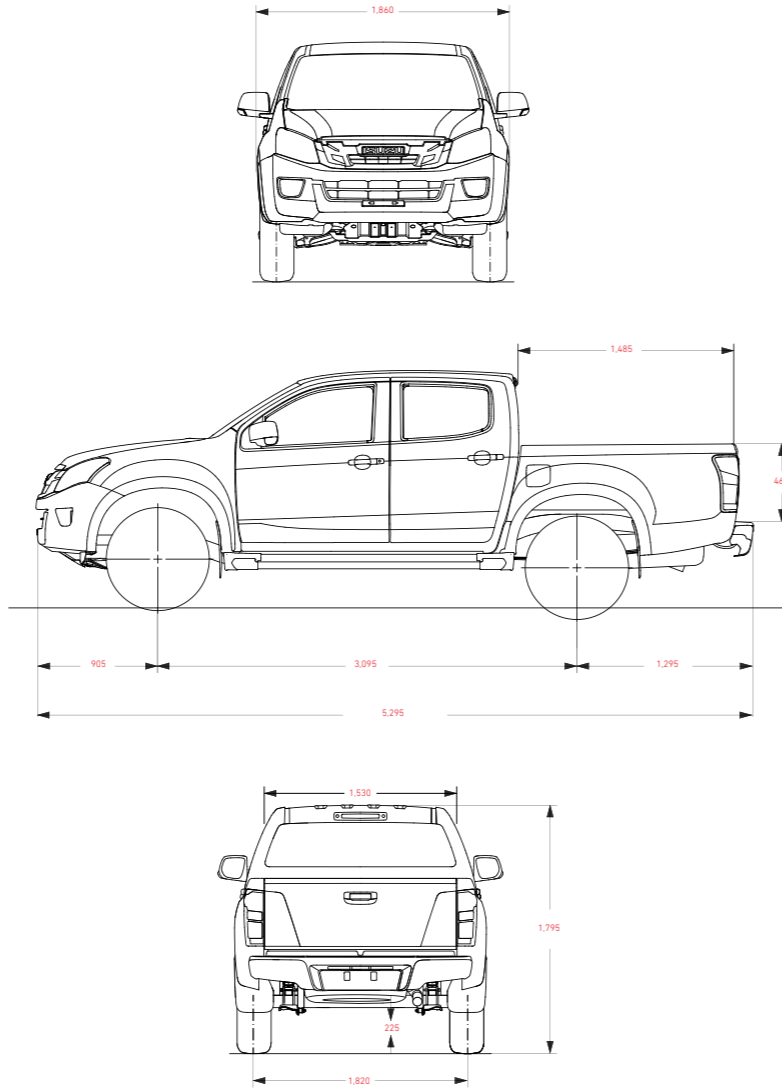

Vehicle dimensions vary according to the types of optional equipment fitted.

TECHNICAL SPECIFICATIONS

	ISUZU D-MAX FURY 4x4 Double Cab 6MT	ISUZU D-MAX FURY 4x4 Double Cab 5AT
ENGINE		
Variant/version	86C/WMD140B5UCB	86C/WAD260B5UCB
Engine type	4JK1	4JK1
Capacity/power	2.5 litre/163 PS diesel	2.5 litre/163 PS diesel
Type	DOHC	DOHC
Construction	Cast iron cylinder block and aluminium head	
Arrangement cylinders	4 in-line	4 in-line
Firing order	1-3-4-2	1-3-4-2
Valves (4 per cylinder)	16	16
Bore	mm	95.4
Stroke	mm	87.4
Compression	17 +/- 0.6	17 +/- 0.6
Engine capacity	cm ³	2499
Net power	kW	120@3600
Net power	PS	163.15@3600
Torque	Nm	400@1400-2000
Torque	lb/ft	295@1400-2000
Top speed	mph	112
Idle speed	700 +/- 25	700 +/- 25
EMISSIONS		
Emissions class	Euro Stage5+	Euro Stage5+
Fuel tank capacity	litres (Gal)	69 (15.18)
FUEL CONSUMPTION L/100 KM (MPG)*		
Urban cycle	8.9 (31.7)	10.5 (26.9)
Extra urban cycle	6.4 (44.1)	7.2 (39.2)
Combined cycle	7.3 (38.7)	8.4 (33.6)
CO ₂ emissions	g/km	192
Maximum vehicle speed	Km/h (mph)	180 (111.78)
GEAR RATIOS		
1	5.232	3.52
2	2.644	2.042
3	1.606	1.400
4	1.219	1.000
5	1.000	0.716
6	0.728	NA
Reverse	4.525	3.224
Final drive	3.071	3.727

	ISUZU D-MAX FURY MANUAL	ISUZU D-MAX FURY AUTOMATIC
DIMENSIONS		
Length	mm	5295
Width	mm	1860
Height	mm	1795
Front overhang	mm	905
Rear overhang	mm	1295
Wheelbase	mm	3095
Wading depth	mm	600

4X4 DETAILS		
Ground clearance	mm (rear axle)	235
Approach angle	Degrees	30
Departure angle	Degrees	23
Ramp angle	Degrees	22

WEIGHTS		
Kerb weight**	kg	1978
Gross vehicle weight	kg	3050
Payload	kg	1072
Maximum front axle	kg	1350
Max rear axle	kg	1870
Trailer weight braked	kg	3500
Trailer weight unbraked	kg	750
Nose weight	kg	245
Gross train weight	kg [†]	6000

WHEEL, TYRE AND TURNING		
Tyres	255/65 R17	255/65 R17
Wheels	17x7 J	17x7 J
Track front	mm	1570
Track rear	mm	1570
Min. turning circle (m) dia. (radius) kerb to kerb	12.2	12.2

*MPG figures are official EU test figures for comparative purposes and may not reflect real driving results.

[†]Gross Train Weight (GTW). The total permissible all-up weight of a rigid vehicle together with trailer and load. Trailers of the above capacities should be used within the plated GTW. Dependant on the drive line combination and payload carried by the prime mover, it may not be possible to tow trailers of the maximum capabilities mentioned.

**Kerb weights vary according to the types of optional extras fitted.

*Available at additional cost. Limited availability.



isuzu.co.uk



Isuzu (UK) Ltd reserve the right to change specifications and equipment without notice. Details of specifications and equipment mentioned or shown in this brochure may be subject to change. Features and specification may vary in appearance and/or availability. Accessories and equipment shown in this brochure have been used for illustrative purposes only. 5 year/125,000 miles (whichever occurs first) warranty applies to all new Isuzu D-Max models. Terms and conditions apply. See isuzu.co.uk for full details. Please enquire at your local Isuzu dealer for details on available models and their specifications.

Part No. IB517

ISUZU
THE PICK-UP
PROFESSIONALS